

DERRINGER PACKAGE

LASER DIODE ARRAY

900W QCW

NORTHROP GRUMMAN

PART NUMBER: ARR01P900
9-BAR DERRINGER PACKAGE

FEATURES AND BENEFITS

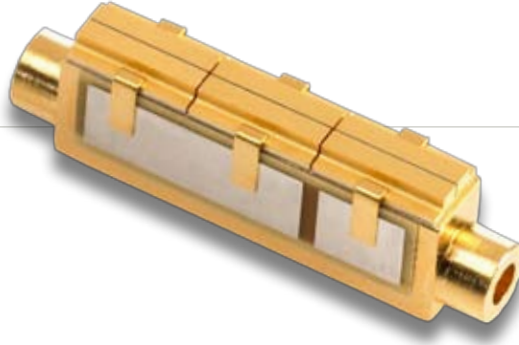

- Assembled With Hard Solder & Expansion Matched Materials
- Ideal For Long Pulse And/Or High Duty Cycle Applications
- Multi-wavelength Configurations Available From 790-1550nm
- Standard Bar Pitch Options Include 400 μm , 800 μm , and 1200 μm
- Small, Compact Water Cooled Design Is Ideal For Side Pumping Or Direct Diode Applications
- Derringer Package Available With Up To 24 Bars And A Maximum Output Power Of 4.8 kW

OPTICAL CHARACTERISTICS

Parameter	Conditions	Typical	Units
QCW Power Output	95A at 25°C Heat Sink	900	W
Operating Current	900W at 25°C Heat Sink	95	A
Threshold Current	25°C Heat Sink	15	A
Slope Efficiency	25°C Heat Sink	11.3	W/A
Electrical-Optical Efficiency	900W at 25°C Heat Sink	58	%
Center Wavelength	900W at 25°C Heat Sink	808	nm
Wavelength Tolerance	900W at 25°C Heat Sink	+/-3	nm
Spectral Width	900W at 25°C Heat Sink	2.0	nm
Wavelength Shift	—	0.25	nm/°C
Beam Divergence FWHM	—	38x7	x°
Beam Divergence FWHM (Lensed)	—	1x7	x°

ELECTRICAL CHARACTERISTICS

Parameter	Conditions	Typical	Units
Series Resistance	25°C Heat Sink	0.018	Ω
Operating Voltage	25°C Heat Sink, 900W	16.2	V

ABSOLUTE MAXIMUM RATINGS

Parameter	Conditions
Reverse Current	0 A
Reverse Voltage	0 V
Operating Temperature Range	-40°C to 70°C
Storage Temperature Range	-40°C to 85°C

NOTES

- (1) These specifications apply for operation at 808nm. Other wavelengths available upon request.
- (2) A dry nitrogen environment should be provided by the user when storing and operating at temperatures below ambient dew point.
- (3) Fast axis and slow axis lensing options are available for most NG-CEO heat exchanger designs.

900W QCW

NORTHROP GRUMMAN

OPTICAL CHARACTERISTICS (SAMPLE)

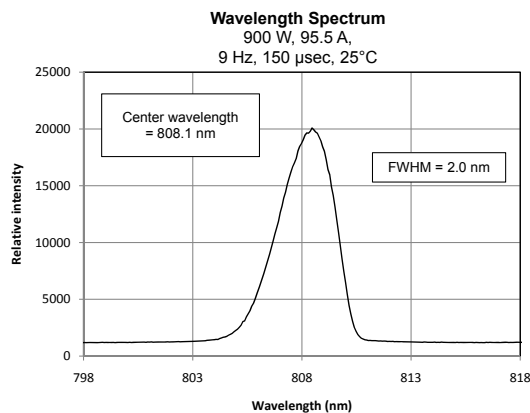
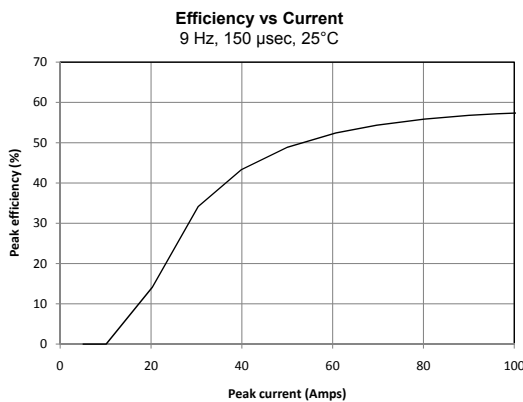
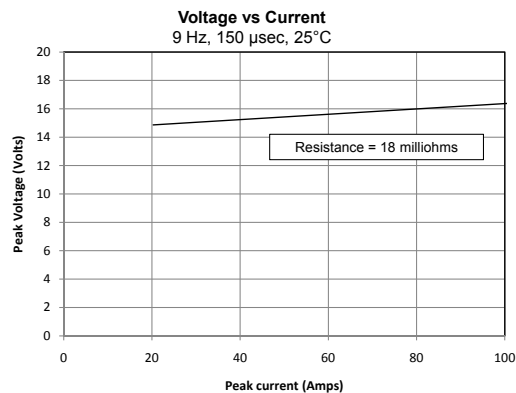
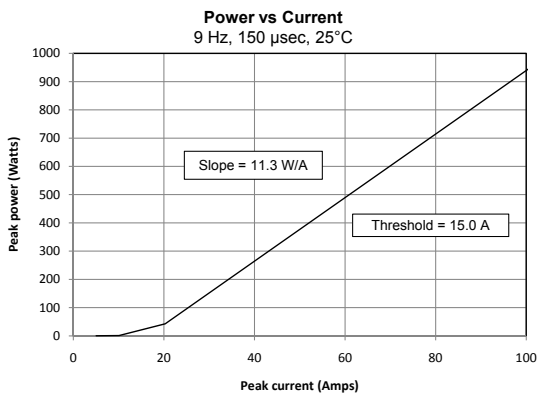

MECHANICAL CHARACTERISTICS

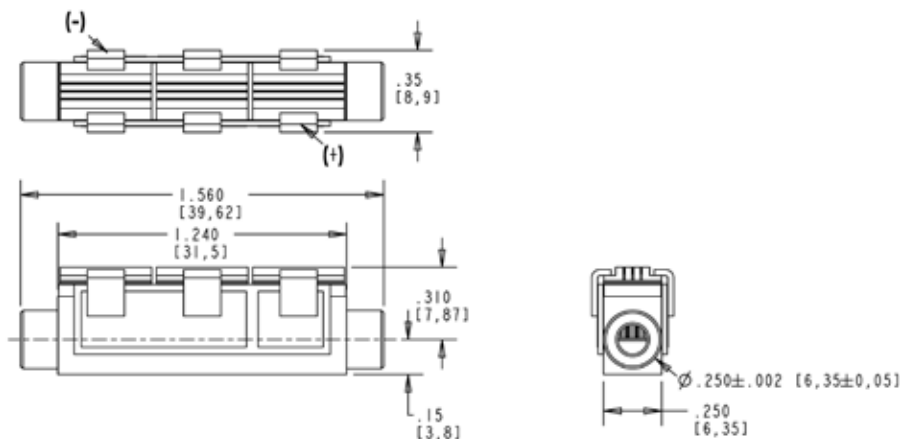

Copyright © 2008 Northrop Grumman Cutting Edge Optronics All Rights Reserved. Northrop Grumman Cutting Edge Optronics reserves the right to change product design and specifications at any time without notice. No license is granted by implication or otherwise under any patents or patent rights of Northrop Grumman Cutting Edge Optronics or others. No responsibility is assumed for the use of these products, nor for any infringement on the rights of others resulting from the use of these products. Information contained herein is believed to be reliable and accurate. Laser diode product components are intended for use in a user-devised end system. However, these products are capable of emitting Class IV radiation. Extreme care must be exercised during their operation. Only persons familiar with the appropriate safety precautions should operate a laser product. Directly viewing the laser beam or exposure to specular reflections must be avoided. Serious injury may result if any part of the body is exposed to the beam. The eye is extremely sensitive to the infrared radiation and therefore, proper eyewear must be worn at all times. Use of optical instruments with these products may increase eye hazard. Always wear proper eye protection when operating. This Product is covered by one or more of the following Patents: 5,898,211 | 5,985,684 | 5,913,108 | 6,310,900 | Other US and Foreign Patents Pending. Notes (1) These specifications apply for operation at 808nm. Other wavelengths available upon request. (2) A dry nitrogen environment should be provided by the user when storing and operating at temperatures below ambient dew point.

⚠ DANGER ⚠

INVISIBLE LASER RADIATION

AVOID EYE OR SKIN EXPOSURE TO DIRECT OR SCATTERED RADIATION.

* Diode laser
5W & up, 780-1560nm
CLASS IV

⚠ WARNING ⚠

ELECTROSTATIC DISCHARGE SENSITIVE DEVICE
REQUIRING SPECIAL HANDLING

Rev. A 10/09 900W01-1000 Rev0000